

## 1A Adjustable/Fixed Low Dropout Linear Regulator

### General Description

The AMS1117-ADJ and AMS1117-1.2,-1.5,-1.8,-2.5,-2.85,-3.3 and-5 are low dropout three-terminal regulators with 1A output current capability. These devices have been optimized for low voltage where transient response and minimum input voltage are critical. The 2.85V version is designed specifically to be used in Active Terminators for SCSI bus.

On-chip thermal limiting provides protection against any combination of overload and ambient temperatures that would create excessive junction temperatures.

Unlike PNP type regulators where up to 10% of the output current is wasted as quiescent current, the quiescent current of the AMS1117 flows into the load, increasing efficiency.

The AMS1117 series regulators are available in the industry-standard SOT-223 and TO-252 power packages.

### Key Features

- Low dropout voltage
- Load regulation: 0.2% typical
- Optimized for Low Voltage
- On-chip thermal limiting
- Standard SOT-223 and TO-252 packages
- Three-terminal adjustable or fixed low dropout 1.2V,1.5V,1.8V, 2.5V, 2.85V, 3.3V, 5V. Regulators

### Applications

- Active SCSI terminators
- High efficiency linear regulators
- Post regulators for switching supplies
- Battery chargers
- 12V to 5V linear regulators
- Motherboard clock supplies

### Typical Application

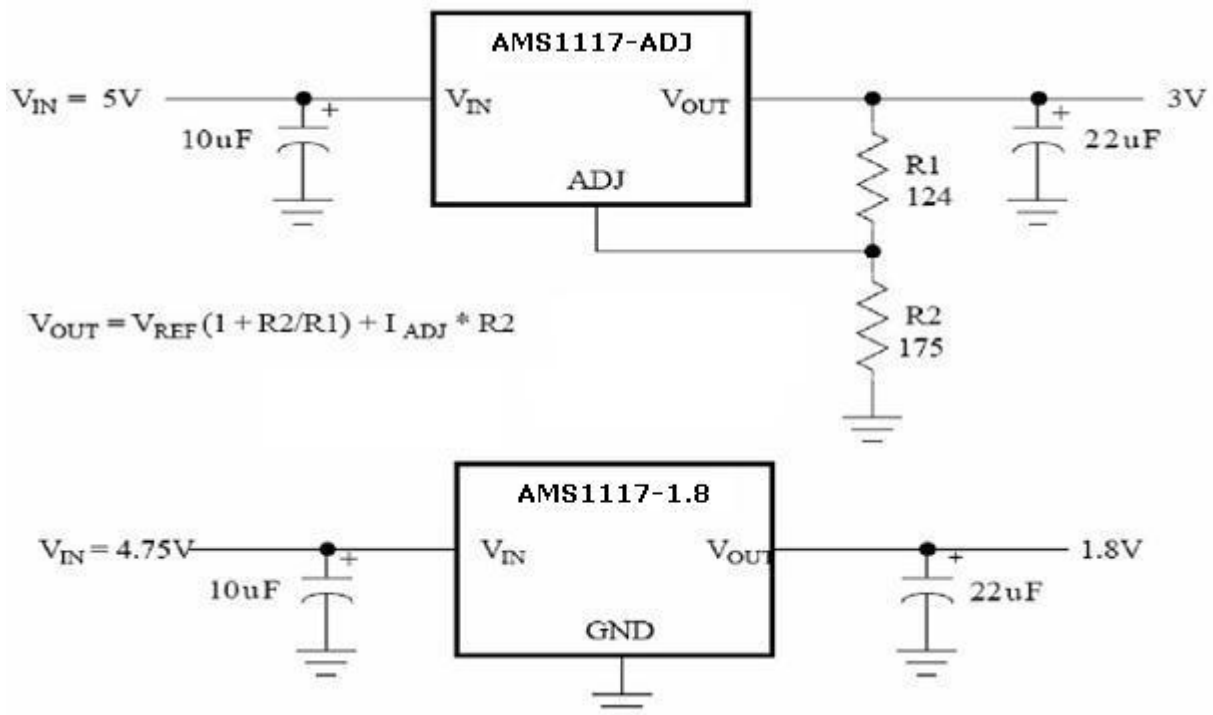
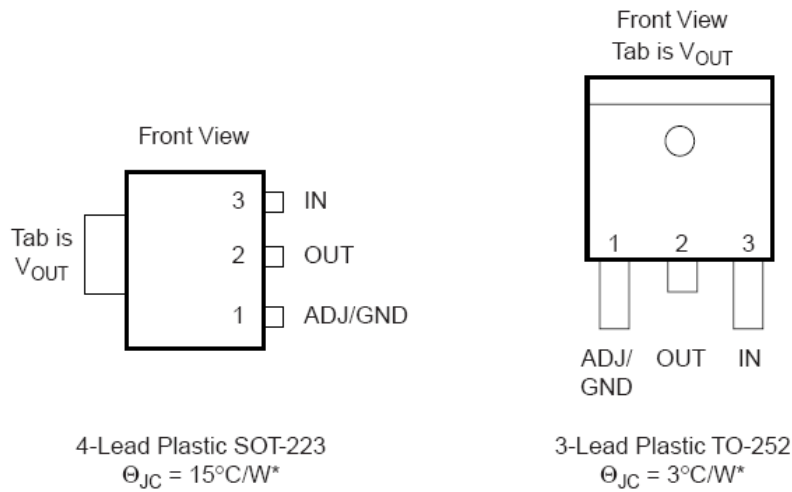

Figure 1. Typical Applications of AMS1117

Notice: The distance between Vout pin and Capacitor should not exceed 4cm for excellent performance

## 1A Adjustable/Fixed Low Dropout Linear Regulator

### Pin Assignments



**Figure 2.** Pin Assignments of AMS1117

\*With package soldered to 0.5 square inch copper area over backside ground plane or internal power plane,  $\theta_{JA}$  can vary from  $30^{\circ}\text{C/W}$  to more than  $50^{\circ}\text{C/W}$ . Other mounting techniques may provide better thermal resistance than  $30^{\circ}\text{C/W}$ .

### Absolute Maximum Ratings

Parameter	Min.	Max.	Unit
$V_{IN}$		18	V
$(V_{IN} - V_{OUT}) * I_{OUT}$		See Figure 3	
Operating Junction Temperature Range	-20	125	$^{\circ}\text{C}$
Storage Temperature Range	-65	150	$^{\circ}\text{C}$
Lead Temperature (Soldering, 10 sec.)		300	$^{\circ}\text{C}$

## 1A Adjustable/Fixed Low Dropout Linear Regulator

### Block Diagram

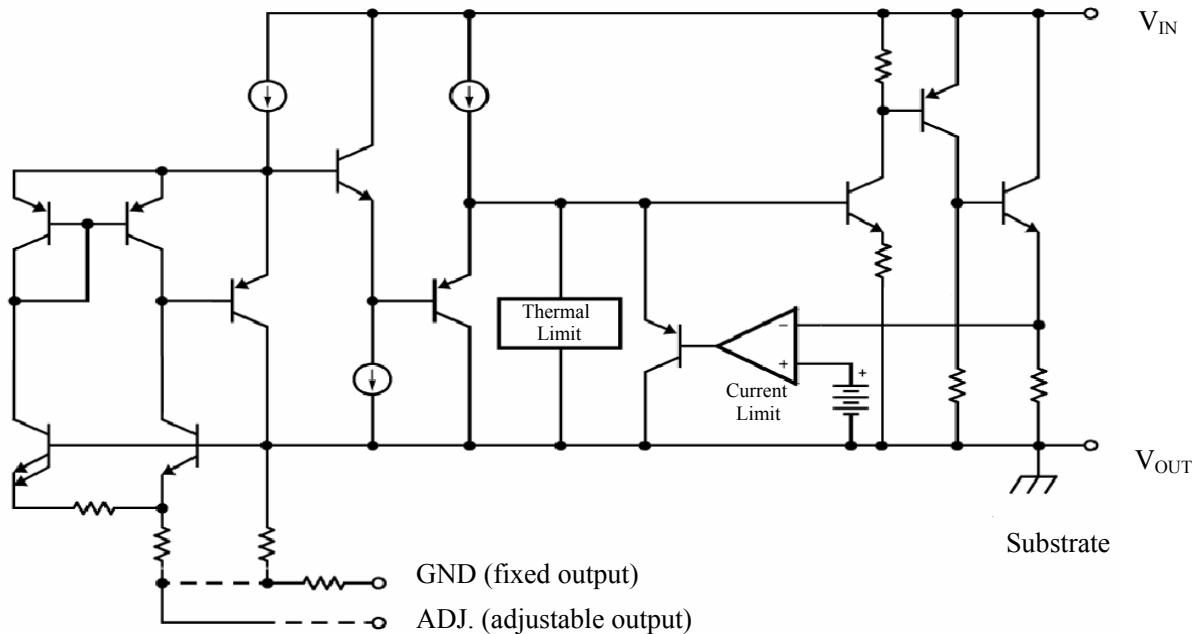

Figure 3. Block Diagram of AMS1117

### Electrical Characteristic

Typicals and limits appearing in normal type apply for  $T_J=25^\circ\text{C}$ . Limits appearing in Boldface type apply over the entire junction temperature for operation,  $-20^\circ\text{C}$  to  $125^\circ\text{C}$ .

Symbol	Parameter	Conditions	Min (Note 2)	Typ (Note 1)	Max (Note 2)	Units	
$V_{REF}$	Reference Voltage	AMS1117 $1.5V \leq (V_{IN} - V_{OUT}) \leq 7V, 10mA \leq I_{OUT} \leq 1A$	<b>1.225</b>	1.250	<b>1.275</b>	V	
$V_{OUT}$	Output Voltage	$10mA \leq I_{OUT} \leq 1A$	$I_{OUT} = 10mA, V_{IN} = 3.2V$	<b>1.176</b>	1.200	<b>1.224</b>	V
			AMS1117-1.2, $2.7V \leq V_N \leq 8.2V$	<b>1.152</b>	1.200	<b>1.248</b>	V
			AMS1117-1.5, $3.0V \leq V_N \leq 8.5V$	<b>1.470</b>	1.500	<b>1.530</b>	V
			AMS1117-1.8, $3.3V \leq V_N \leq 8.8V$	<b>1.764</b>	1.800	<b>1.836</b>	V
			AMS1117-2.5, $4V \leq V_N \leq 9.5V$	<b>2.450</b>	2.500	<b>2.550</b>	V
			AMS1117-2.85, $4.35V \leq V_N \leq 9.85V$	<b>2.793</b>	2.850	<b>2.907</b>	V
			AMS1117-3.3, $4.8V \leq V_N \leq 10.3V$	<b>3.234</b>	3.300	<b>3.366</b>	V
			AMS1117-5.0, $6.5V \leq V_N \leq 12V$	<b>4.900</b>	5.000	<b>5.100</b>	V



# 1A Adjustable/Fixed Low Dropout Linear Regulator

## Electrical Characteristic (Continued)

Typicals and limits appearing in normal type apply for  $T_J=25^\circ\text{C}$ . Limits appearing in Boldface type apply over the entire junction temperature for operation,  $-20^\circ\text{C}$  to  $125^\circ\text{C}$ .

Symbol	Parameter	Conditions	Min (Note 2)	Typ (Note 1)	Max (Note 2)	Units
$\Delta V_{\text{OUT}}$	Line Regulation (Note 3)	$I_{\text{OUT}}=10\text{mA}, (V_{\text{OUT}}+1.5\text{V})\leq V_{\text{IN}}\leq 12\text{V}$		0.035	<b>0.2</b>	%
	Load Regulation (Note 3)	$V_{\text{IN}}-V_{\text{OUT}}=2\text{V}, 10\text{mA}\leq I_{\text{OUT}}\leq 1\text{A},$ AMS1117-1.2		0.2	<b>0.7</b>	%
		$V_{\text{IN}}-V_{\text{OUT}}=2\text{V}, 10\text{mA}\leq I_{\text{OUT}}\leq 1\text{A},$		0.2	<b>1</b>	%
$V_{\text{IN}}-V_{\text{OUT}}$	Dropout Voltage	$I_{\text{OUT}}=1\text{A}, \Delta V_{\text{REF}}=1\%$		1.100	<b>1.250</b>	V
$I_{\text{Limit}}$	Current Limit	$V_{\text{IN}}-V_{\text{OUT}}=2\text{V}, T_J=25^\circ\text{C}$	1.1	1.5		A
	Minimum Load Current (Note 4)	AMS1117-ADJ $1.5\text{V}\leq (V_{\text{IN}}-V_{\text{OUT}})\leq 10\text{V}$	10			mA
	Quiescent Current	$V_{\text{IN}}=V_{\text{OUT}}+1.25\text{V}$		5	<b>13</b>	mA
	Thermal Regulation	$T_A = 25^\circ\text{C}, 30\text{ms pulse}$		0.01	<b>0.1</b>	%/W
	Ripple Rejection	$f=120\text{Hz}, V_{\text{IN}}-V_{\text{OUT}}=3\text{V}, V_{\text{Ripple}}=1\text{V}_{\text{PP}}$	<b>60</b>	72		dB
	Adjust Pin Current			50	<b>120</b>	$\mu\text{A}$
	Adjust Pin Current Change	$1.5\text{V}\leq V_{\text{IN}}-V_{\text{OUT}}\leq 7\text{V}, 10\text{mA}\leq I_{\text{OUT}}\leq 1\text{A}$		0.2	<b>5</b>	$\mu\text{A}$
	Temperature Stability			0.5		%
Long Term Stability	$T_A = 125^\circ\text{C}, 1000\text{hrs.}$		0.3		%	



# 1A Adjustable/Fixed Low Dropout Linear Regulator

## Electrical Characteristic (Continued)

Typicals and limits appearing in normal type apply for  $T_J=25^{\circ}\text{C}$ . Limits appearing in Boldface type apply over the entire junction temperature for operation,  $-20^{\circ}\text{C}$  to  $125^{\circ}\text{C}$ .

Symbol	Parameter	Conditions	Min (Note 2)	Typ (Note 1)	Max (Note 2)	Units
$I_{Limit}$	RMS Output Noise(% of $V_{OUT}$ )	$T_A = 25^{\circ}\text{C}$ , $10\text{Hz} \leq f \leq 10\text{kHz}$		0.003		%
	Thermal Resistance, Junction to Case	SOT-223		15		$^{\circ}\text{C}/\text{W}$
		TO-252		3		$^{\circ}\text{C}/\text{W}$
	Thermal Shutdown	Junction Temperature		155		$^{\circ}\text{C}$
	Thermal Shutdown Hysteresis			25		$^{\circ}\text{C}$

**Note 1:** Typical Values represent the most likely parametric norm.

**Note 2:** All limits are guaranteed by testing or statistical analysis.

**Note 3:** Load and line regulation are measured at constant junction room temperature.

**Note 4:** The minimum output current required to maintain regulation.

## Typical Performance Characteristics

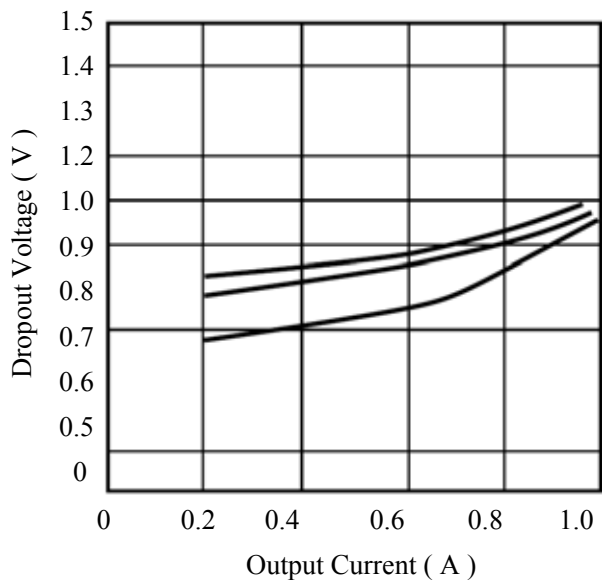

**Figure 4.** Dropout Voltage VS. Output Current



# 1A Adjustable/Fixed Low Dropout Linear Regulator

## Typical Performance Characteristics

(Continued)

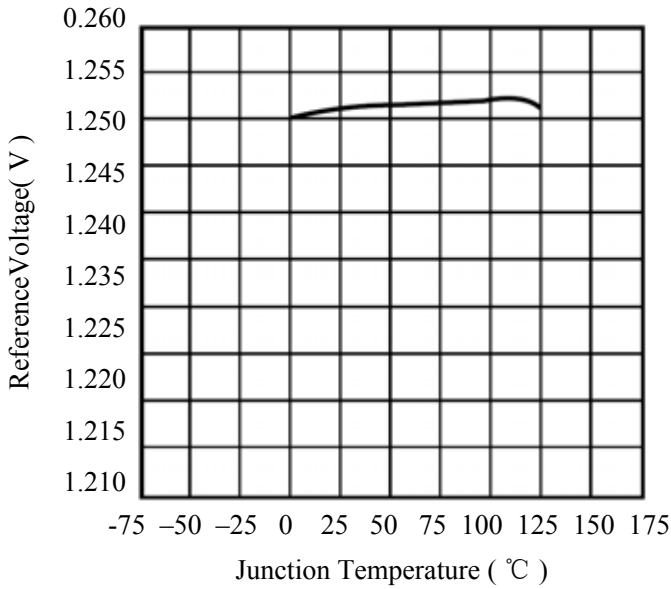

Figure 5. Reference Voltage VS. Temperature

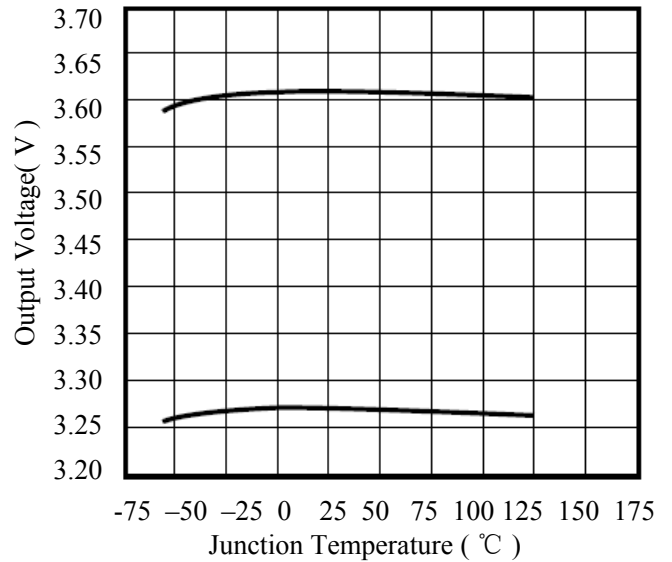

Figure 6. Output Voltage VS. Temperature

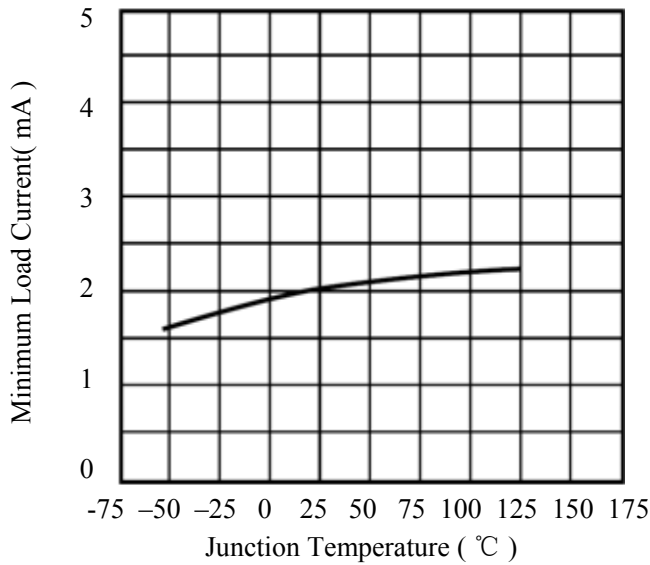

Figure 7. Minimum Load Current VS. Temperature

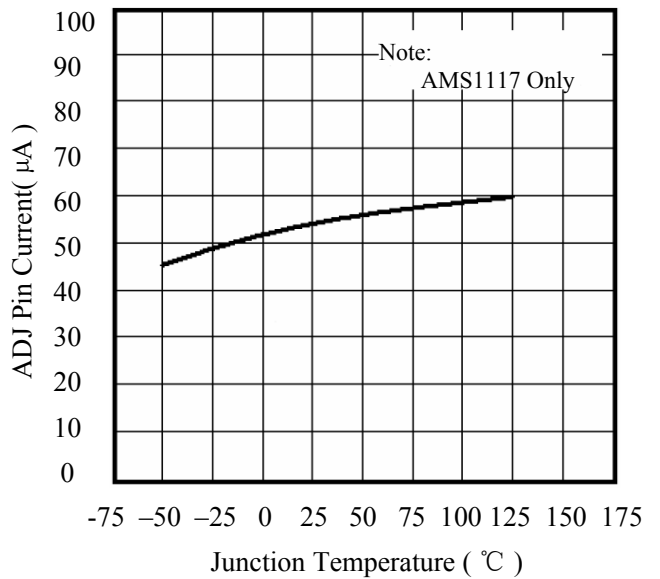

Figure 8. ADJ Pin Current VS. Temperature

# 1A Adjustable/Fixed Low Dropout Linear Regulator

## Mechanical Dimensions

4-Lead SOT-223 Package

Symbol	Inches		Millimeters		Notes
	Min.	Max.	Min.	Max.	
A	Ñ	.071	Ñ	1.80	
A1	Ñ	.181	Ñ	4.80	
B	.025	.033	.064	.840	
c	Ñ	0.90	Ñ	2.29	
D	.248	.264	6.30	6.71	
E	.130	.148	3.30	3.71	
e	.115	.124	2.95	3.15	
F	.033	.041	.840	1.04	
H	.264	.287	6.71	7.29	
I	.0121	Ñ	.310	Ñ	
J	Ñ	10°	Ñ	10°	
K	10°	16°	10°	16°	
L	.0008	.0040	.0203	.1018	
M	10°	16°	10°	16°	
N	.010	.014	.250	.360	

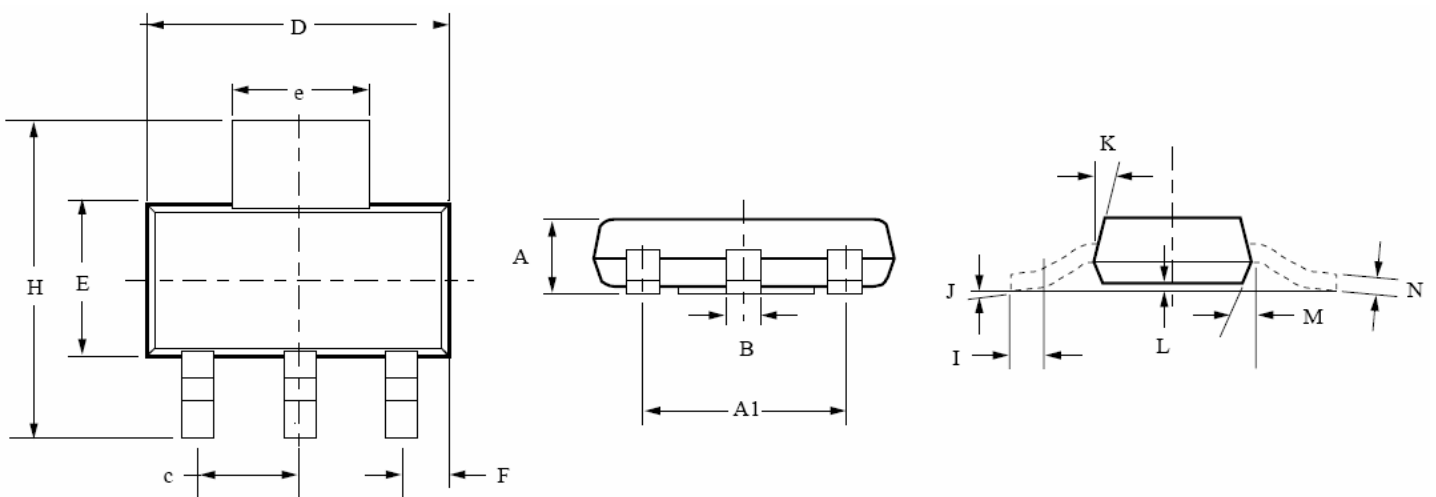

**Figure 9.** 4-Lead SOT-223 Package

## 1A Adjustable/Fixed Low Dropout Linear Regulator

### Mechanical Dimensions (Continued)

3-Lead TO-252 Package

Symbol	Inches		Millimeters		Notes
	Min.	Max.	Min.	Max.	
A	.086	.094	2.19	2.39	
b	.025	.035	0.64	0.89	
b2	.030	.045	0.76	1.14	
b3	.205	.215	5.12	5.46	4
c	.018	.024	0.46	0.61	
c2	.018	.023	0.46	0.58	
D	.210	.245	5.33	6.22	1
E	.250	.265	6.35	6.73	1
e	.090 BSC		2.29 BSC		
H	.370	.410	9.40	10.41	
L	.055	.070	1.40	1.78	3
L1	.108 REF		2.74 REF		
L3	.035	.080	0.89	2.03	4
L4	.025	.040	0.64	1.02	

**Notes:**

1. Dimensions are exclusive of mold flash, metal burrs or interlead protrusion.
2. Stand off-height is measured from lead tip with ref. to Datum -B-.
3. Foot length is measured with ref. to Datum -A- with lead surface.
4. Thermal pad contour optional within dimension b3 and L3.
5. Formed leads to be planar with respect to one another at seating place -C-.
6. Dimensions and tolerances.

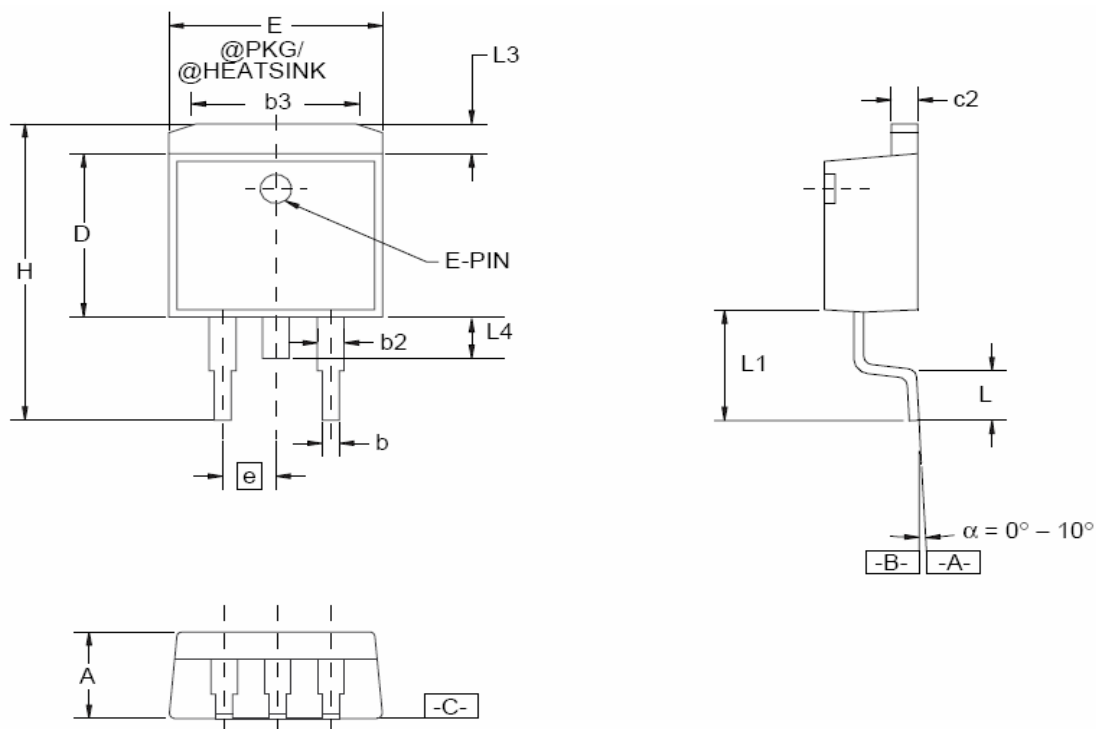

Figure 10. 3-Lead TO-252 Package





## 1A Adjustable/Fixed Low Dropout Linear Regulator

### Ordering Information

Package	Temperature Range	Part Number	Output Voltage	Packing Marking	Transport Media
SOT-223	-20°C - +125°C	AMS1117-1.2	1.2V	AMS1117 1.2	2.5K Tape and Reel
	-20°C - +125°C	AMS1117-1.5	1.5V	AMS1117 1.5	2.5K Tape and Reel
	-20°C - +125°C	AMS1117-1.8	1.8V	AMS1117 1.8	2.5K Tape and Reel
	-20°C - +125°C	AMS1117-2.5	2.5V	AMS1117 2.5	2.5K Tape and Reel
	-20°C - +125°C	AMS1117-2.85	2.85V	AMS1117 2.8	2.5K Tape and Reel
	-20°C - +125°C	AMS1117-3.3	3.3V	AMS1117 3.3	2.5K Tape and Reel
	-20°C - +125°C	AMS1117-5	5V	AMS1117 5	2.5K Tape and Reel
	-20°C - +125°C	AMS1117	Adjust	AMS1117	2.5K Tape and Reel
TO-252	-20°C - +125°C	AMS1117-1.2	1.2V	AMS1117 1.2	2.5K Tape and Reel
	-20°C - +125°C	AMS1117-1.5	1.5V	AMS1117 1.5	2.5K Tape and Reel
	-20°C - +125°C	AMS1117-1.8	1.8V	AMS1117 1.8	2.5K Tape and Reel
	-20°C - +125°C	AMS1117-2.5	2.5V	AMS1117 2.5	2.5K Tape and Reel
	-20°C - +125°C	AMS1117-2.85	2.85V	AMS1117 2.8	2.5K Tape and Reel
	-20°C - +125°C	AMS1117-3.3	3.3V	AMS1117 3.3	2.5K Tape and Reel
	-20°C - +125°C	AMS1117-5	5.0V	AMS1117 5	2.5K Tape and Reel
	-20°C - +125°C	AMS1117CD	Adjust	AMS1117CD	2.5K Tape and Reel

Advanced Monolithic Systems

<http://www.ams-semitech.com>

**Disclaimer:**

- AMS reserves the right to make changes to the information herein for the improvement of the design and performance without further notice! Customers should obtain the latest relevant information before placing orders and should verify that such information is complete and current.
- All semiconductor products malfunction or fail with some probability under special conditions. When using AMS products in system design or complete machine manufacturing, it is the responsibility of the buyer to comply with the safety standards strictly and take essential measures to avoid situations in which a malfunction or failure of such AMS products could cause loss of body injury or damage to property.
- AMS will supply the best possible product for customers!

The "S" logo is a registered trademark of Advanced Monolithic Systems.  
All other company and product names are trademarks of their respective owners